



ITEM NUMBER
BUR100-CT-CA

NESTABLE RETAIL TUB

These tubs are indispensable to the retail industry. Polyethylene construction makes these tubs durable and maintenance-free, but still lightweight.

Rounded corners prevent snags and a diamond texture on the bottom helps keep things in place, but still allows the tub to slide on tables and smooth surfaces. These tubs offer plenty of usable space, but nest to minimize storage space when they are empty.



MADE IN THE USA



Empty tubs nest so you can
store more in less space.

800.798.4900

www.gpi-plastics.com

1126 N. Kimball St.
Danville, IL



NESTABLE RETAIL TUB TECHNICAL SPECIFICATIONS

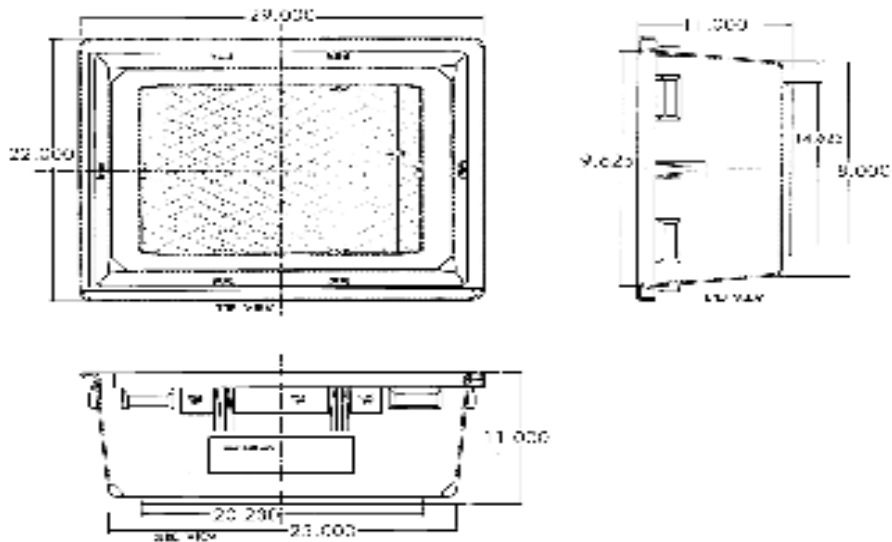

Drawing is not to scale. For reference only.

DIMENSIONS	BUR100-CT-CA
Overall length	29.000"
Overall width	22.000"
Overall height	11.000"
Approx. weight	8.0 lbs.

Features and Benefits

- Maintenance-free
- Crafted from durable, yet lightweight polyethylene
- Rounded corners prevent snagging and injury
- Flat bottom allows for easy sliding on belts and surfaces
- The diamond texture inside the bottom of the tub helps stabilize contents
- Empty tubs nest so you can store more tubs in less space
- Smooth exterior easy to label on any side

OPTIONS

- Logo area allows you to brand each tub with your corporate identity



About GPI

Greenwood Plastics Industries is family-owned and operated. Located in Central Illinois, GPI manufactures durable, lightweight products to fill the needs of a variety of industries, including airlines, retail, food distribution, healthcare and funeral service.